



Dock Boxes Unlimited™

Coming together is a beginning. Keeping together is progress. Working together is success.



Installation Instructions for the Hatteras® Light Power Pedestal (#70-8631)

⚠ DANGER



Hazardous voltage. Can cause severe injury or death.

Turn off main power before opening panel.

⚠ WARNING

Dock Boxes Unlimited, Inc. strongly recommends that these products be installed by a qualified electrician.

IMPORTANT - INSTALL EQUIPMENT IN CONFORMANCE WITH CODES

This product must be installed in accordance with the National Electric Code (NEC) or the Canadian Electrical Code (CECO) and any applicable local codes. Before installing equipment, check with your local electrical inspector for requirements and information. If you have questions or need assistance, contact a qualified electrician.

⚠ WARNING

Turn off or disconnect the power supplying this equipment before beginning work.

This may require that you contact your electric utility to disconnect power to an existing load-center. The line side of the main breaker is energized unless power is disconnected upstream. Dock Boxes Unlimited, Inc. will not assume responsibility for property damage or personal injury resulting from misuse of the information in this publication.

Wiring Diagram

Wire Colors

(Line 1)	L1	Black
(Neutral)	N	White
(Line 2)	L2	Red
(Line 3)	L3	Blue
(Ground)	G	Green

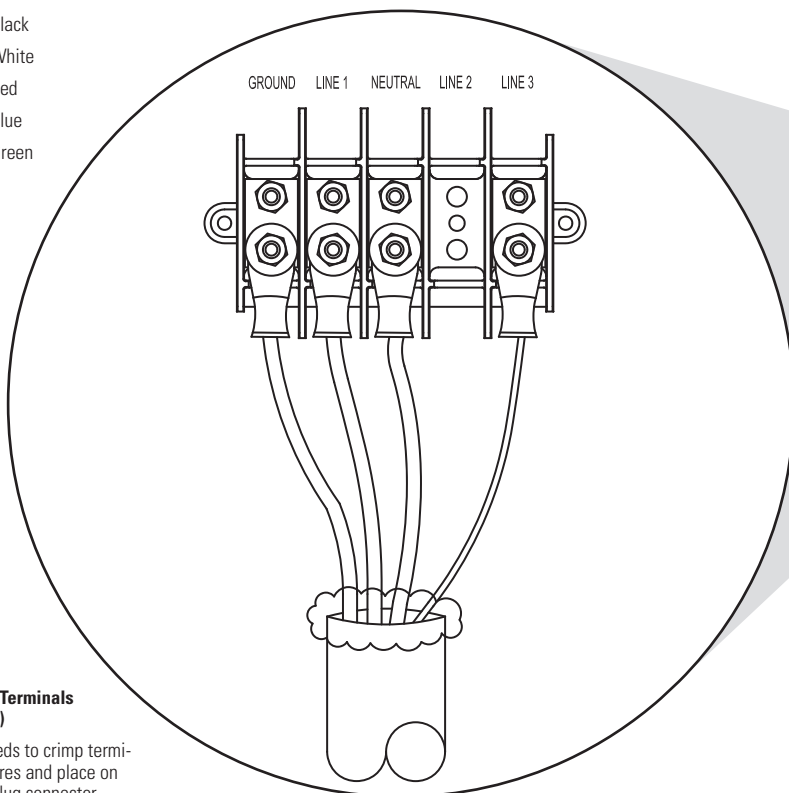

Compression Terminals (Not Included)

Contractor needs to crimp terminals to line wires and place on provided stud lug connector.

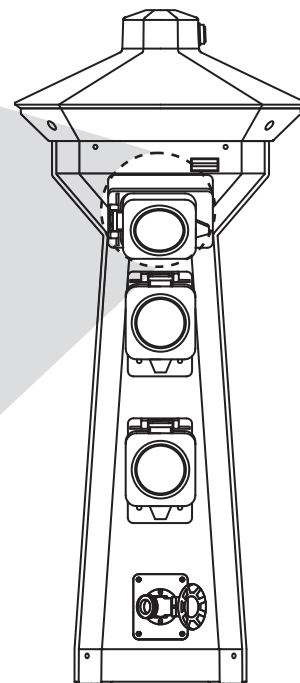

Installation

! Note

We strongly recommend that a qualified electrical contractor install this unit.

1 Securing the Base and Mounting the Pedestal:

! Note

Always use stainless steel mounting hardware and a stainless steel washer between the bolt head and the mounting feet.

See the Base Diagram on Page 3. Suggested locations for the power supply as well as water, phone and cable TV utilities are identified. We recommend that you prepare the mounting of the base as follows:

• On Concrete Docks

At each corner, utilize four 1/4" compression bolts or threaded rod set in the concrete on 7" x 7 3/8" centers (see base layout drawing) for through-hole mounting of the Hatteras Light base.

• On Wood Docks

At each corner, utilize four 1/4" bolts or lag screws on 7 3/8" center for through-hole mounting of the Hatteras Light base. Always use stainless bolts and washers to prevent damage while mounting the base.

• On Both Concrete and Wood Docks

The mounting surface must be flat and level. If cupped deck boards or an irregular concrete surface are under the base mount feet, stainless washers should be used to

shim the base level before the tightening the mounting bolts or screws.

2 Connecting Power Supply to the Pedestal Buss Bars:

While the top section of the unit is off, remove the plastic plate cover that is inside the top of the pedestal shaft. This will expose the buss bars in the top "neck" of the pedestal so that the installer can connect the power line to the buss bars 1/4" studs. The buss bar is identified L1, L2, N, Ground, make sure that the supply lines are connected to the proper buss lug.

3 Water, Phone/Cable TV Access:

! Note

Water installation can be simplified by attaching a flexible hose from your waterline to the back of the faucet.

The water faucet is mounted on a panel that is attached to the pedestal with four screws. The phone/cable TV base and cover are also mounted to the pedestal with four screws. Remove the water or phone/cable TV panel to access the backside of the utility for connection.

4 Installing the 13-Watt Compact Fluorescent Light

Replace the bulb about every three years, or if the bulb fails to illuminate by unscrewing the lens and top assumedly from the main housing with a Phillips head screwdriver. Once the top is removed, clean as necessary and replace bulb with the recommended compact florescent.

Maintenance

Dock Boxes Unlimited, Inc. produces units that are designed to withstand the harsh marine environment. Very little maintenance is required to keep the units looking new for many years and to keep the warranty effective.

1 Exterior Maintenance

To remove of dirt, grime, and bird droppings, use a mild solution of dishwashing detergent at approximately one teaspoon per gallon of warm water. Once clean, follow up with a water based insect spray to kill the spiders around the base and main housing of the unit.

DO NOT use a petroleum based insect spray.

DO NOT use any solvent or corrosion inhibiting products on any part of the unit. This can cause serious stress cracking of the engineered resins and will void warranty.

2 Interior Maintenance

Before attempting the following maintenance procedures, turn off the power to the unit at the power supply panel.

! Note

The breakers on the unit DO NOT turn the unit power supply off and the buss bars will be energized.

• Exposing the Buss Bar Assembly

Annually, remove the light assembly (4 screws at base of light) and the plastic barrier to expose the buss bars

• Maintenance of Buss Bar Assembly

On all units, the buss bars should be visually examined for excessive heating. If

potentially faulty or loose joints are found, they should be tightened or replaced.

In the cases where mechanical lugs instead of the stud-lug buss assembly are used, it is very important that they be examined closely. Most mechanical lugs are made of aluminum and are very susceptible to galvanic corrosion.

If the set screw cannot be tightened, replace the lug. If there appears to be corrosion around the copper to aluminum connection, remove the copper wire and clean the wire, coat the wire with an anti-corrosion grease, and retighten the assembly.

• Receptacles and Breakers

The receptacles and breakers should be examined annually, and if any sign of heating is evident, the receptacles or breakers should be replaced.

• Solvents

DO NOT spray any solvents on the electrical components. Solvents will cause stress cracking of the polymeric materials and will void warranty.

3 Lighting Assembly

To test the lighting assembly, the photocell should be covered with a piece of black tape and in about 2-3 minutes the light should illuminate. If this does not occur, the following items should be checked: photocell and bulb.

4 Winterizing

The water system should be purged with air and each ball valve should be opened and closed after the system has been drained. This will remove the slug of water that remains in the ball. No other winterizing functions are required.

Dimensions

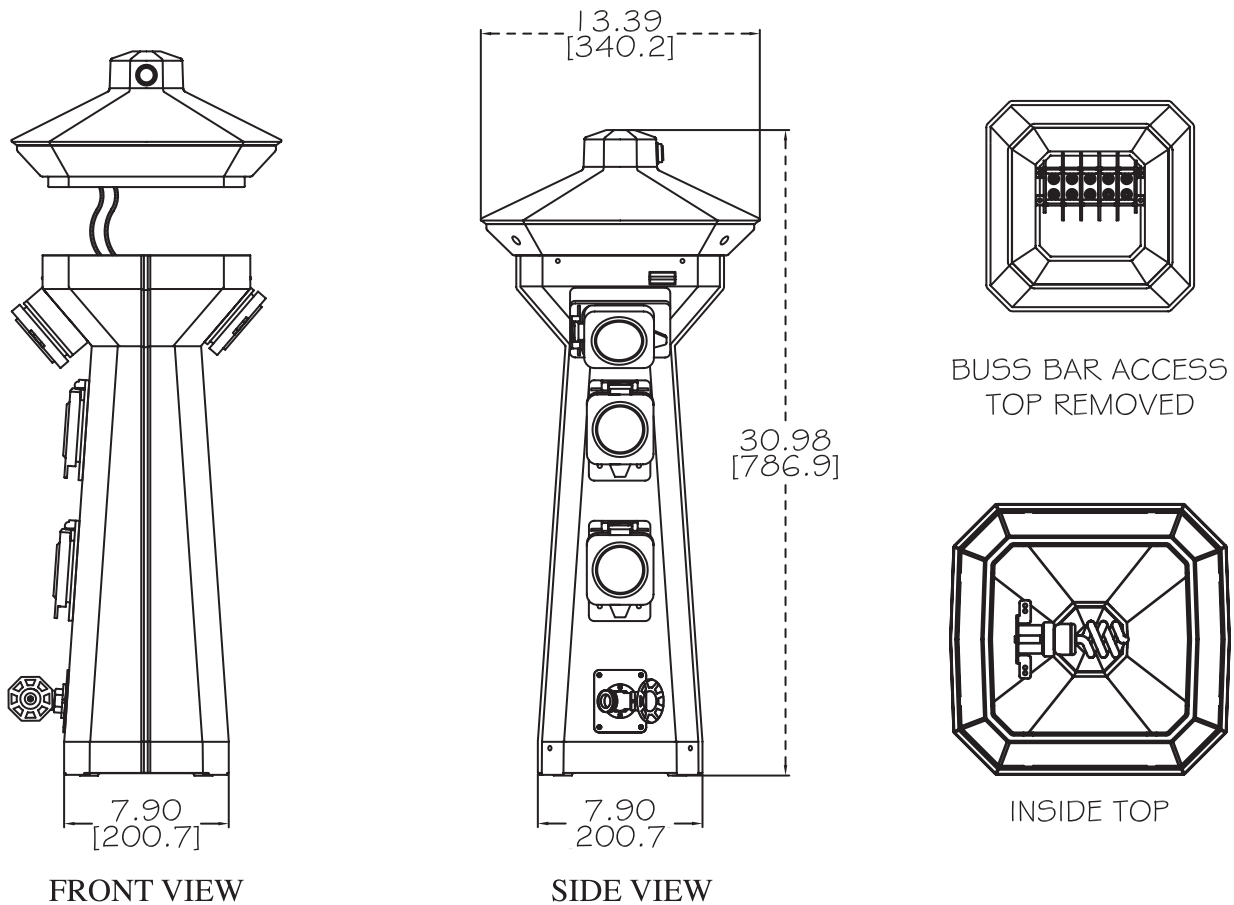

Operation

1 Connect Power Cord to Boat

Insert the proper end of the shore power cord into the boat's power inlet connection, twist the plug to lock, then tighten the locking plug retainer by twisting the large nut until the unit is tight to the boat.

2 Connect Power Cord to Pedestal

With the breakers off, insert the shore power cord into the receptacle and twist the plug clockwise until the plug locks into the receptacle.

3 Turn Breaker ON

With both connections secured, turn on the breaker. The power indicator on the boat should indicate a successful attachment of the plug and the receptacle.

Parts

Save 10% When You Buy Parts and Pedestals Online!

Please visit www.dockboxes.com for a full parts listing.

To request a parts handbook:

- Call 1-800-559-4269 or
- E-mail sales1@ultimatemarinesource.com

Warranty Policy

Dock Boxes Unlimited, Inc. ("Seller") Warranty Policy Supplement to Seller's Selling Policy 25-000.

This Warranty Policy is intended to only supplement and/or alter the "Warranty" provision of Seller's Selling Policy 25-000. All other terms and conditions contained in the Selling Policy 25-000 remain in full force and effect.

Warranty for Pedestals and Distribution Equipment Housings for Dock Boxes Unlimited, Inc. Products

Seller warrants that the housings of all Pedestals and Distribution Equipment manufactured by it ("Housings") will conform to Seller's applicable specifications and be free from failure due to defects in workmanship and material for the lifetime of the Product.

In the event the Housing fails to comply with the foregoing warranty Seller will, at its option, either (a) repair or replace the defective Housing, or defective part or component thereof, F.O.B. Seller's facility freight prepaid, or (b) credit Buyer for the purchase price of the Product. All warranty claims for Housings shall be made in writing. Seller requires all non-conforming Products be returned at Seller's expense for evaluation unless specifically stated otherwise in writing by Seller.

This warranty does not cover failure or damage due to storage, installation, operation or maintenance not in conformance with Seller's recommendations and industry standard practice or due to accident, misuse, abuse or negligence. This warranty does not cover reimbursement for labor, gaining access, removal, installation, temporary power or any other expenses, which may be incurred in connection with repair or replacement.

This warranty does not apply to equipment not manufactured by Seller. Seller limits itself to extending the same warranty it receives from the supplier.

Warranty for Internal Components for Dock Boxes Unlimited, Inc. Products

Dock Boxes Unlimited, Inc. internal component products are covered under the warranty set forth in Seller's Selling Policy 25-000.

Warranty for Meters for Dock Boxes Unlimited, Inc. Products

Seller warrants that the meters manufactured by it ("Meters") will conform to Seller's applicable specifications and be free from failure due to defects in workmanship and material for five (5) years.

In the event a Meter fails to comply with the foregoing warranty Seller will, at its option, either (a) repair or replace the defective Meter, or defective part or component thereof, F.O.B. Seller's facility freight prepaid, or (b) credit Buyer for the purchase price of the Product. All warranty claims for Meters shall be made in writing. Seller requires all non-conforming Products be returned at Seller's expense for evaluation unless specifically stated otherwise in writing by Seller.

This warranty does not cover failure or damage due to storage, installation, operation or maintenance not in conformance with Seller's recommendations and industry standard practice or due to accident, misuse, abuse or negligence. This warranty does not cover reimbursement for labor, gaining access, removal, installation, temporary power or any other expenses, which may be incurred in connection with repair or replacement. This

Warranty is void if factory seal is broken. This warranty does not cover wire harnesses, Current Transformers (CTs) and counters. These components are covered under selling policy 25-000.

This warranty does not apply to equipment not manufactured by Seller. Seller limits itself to extending the same warranty it receives from the supplier.

Dock Boxes Unlimited, Inc.
5605 North MacArthur Blvd., Ste 200
Irving, TX 75038-2630
United States
1-800-559-4269
fax: 972-402-9995
www.dockboxes.com
sales1@ultimatemarinesource.com

**Telephone and Cable TV
Assembly**

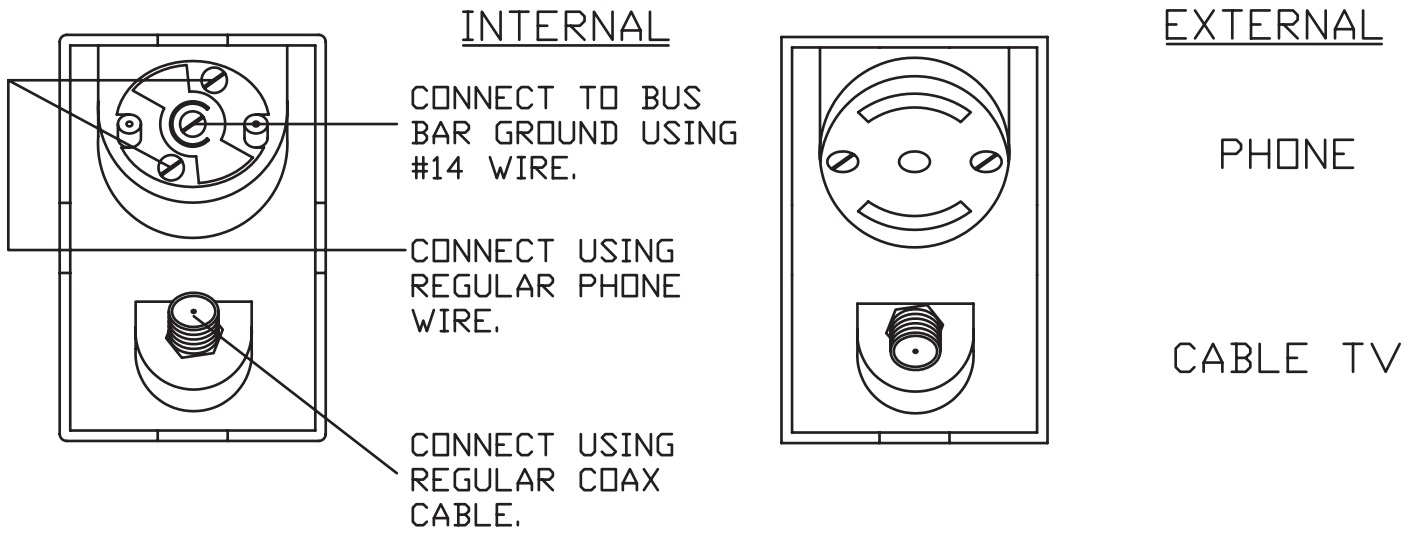

Water Assembly

