



Dock Boxes Unlimited™

Coming together is a beginning. Keeping together is progress. Working together is success.



Installation Instructions for the Firehouse (#70-8635)

⚠ DANGER



Hazardous voltage. Can cause severe injury or death.

Turn off main power before opening panel.

⚠ WARNING

Dock Boxes Unlimited, Inc. strongly recommends that these products be installed by a qualified electrician.

IMPORTANT - INSTALL EQUIPMENT IN CONFORMANCE WITH CODES

This product must be installed in accordance with the National Electric Code (NEC) or the Canadian Electrical Code (CECO) and any applicable local codes. Before installing equipment, check with your local electrical inspector for requirements and information. If you have questions or need assistance, contact a qualified electrician.

⚠ WARNING

Turn off or disconnect the power supplying this equipment before beginning work.

This may require that you contact your electric utility to disconnect power to an existing load-center. The line side of the main breaker is energized unless power is disconnected upstream. Dock Boxes Unlimited, Inc. will not assume responsibility for property damage or personal injury resulting from misuse of the information in this publication.

Wiring Diagram

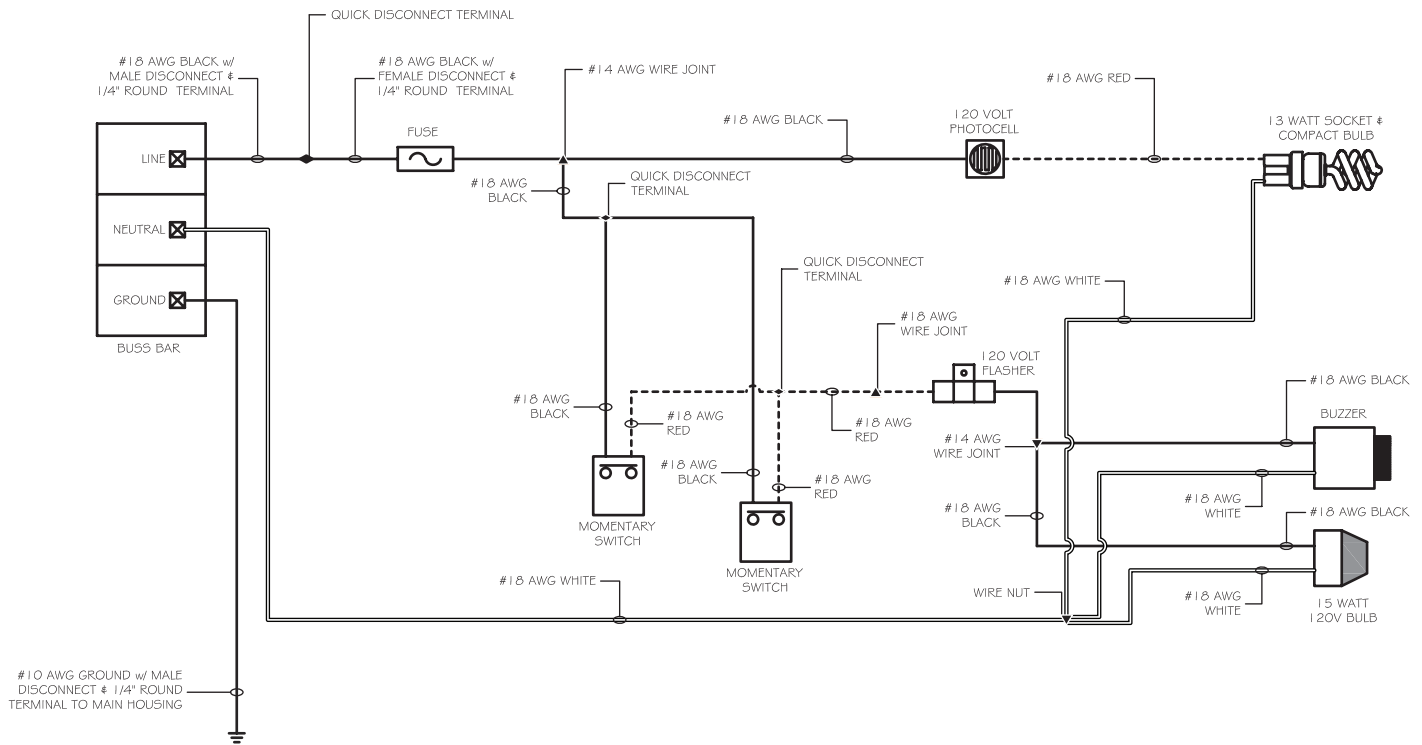

Installation

! Note

We strongly recommend that a qualified electrical contractor install this unit.

1 Mounting the Unit

! Note

Always use stainless steel mounting hardware and a stainless steel washer between the bolt head and the mounting feet.

The unit is shipped with mounting feet attached to the housing. Secure the mounting feet to the dock with a bolt or lag screw through each of the four 1/2" holes (with the mounting plate studs facing up). The four holes in the mounting feet can be used as a drill guide template or as a template guide for casting studs in concrete.

• On Concrete Docks

At each corner, utilize four 3/8" stainless steel compression bolts, or threaded rod set in the concrete on 5" x 10 1/2" centers for through-hole mounting of the Firehouse base.

• On Wood Docks

At each corner, utilize four 3/8" stainless steel bolts or lag screws on 10 1/2" x 5" centers for through-hole mounting of the Firehouse base.

• On Both Concrete and Wood Docks

The mounting surface must be flat and level. If cupped deck boards or an irregular concrete surface are under the base mount

feet, stainless washers should be used to shim the base level before the tightening the mounting bolts or screws.

2 Connecting Power Supply to the Firehouse SS

Remove the four screws holding the lens top to the unit.

Remove the four screws holding the access panel to the bottom front of the unit.

Pass the supply wires through the channel located in the back of the base section until sufficient wire exits the top of the channel located at the bottom of the light assembly.

Place the unit and secure the mounting screws to the dock.

Connect the wires to the appropriate line, neutral, and ground terminals and insert the 13 Watt compact fluorescent light provided in the lens assembly.

Reinstall both the lower access panel and the light assembly.

! Note

If difficulty is encountered when running the wires in the channel, remove the small plate located about three-quarters of the way up the channel to help the wires by the switch assembly. Reinstall the cover plate after wiring.

Maintenance

Dock Boxes Unlimited, Inc. produces units that are designed to withstand the harsh marine environment. Very little maintenance is required to keep the units looking new for many years and to keep the warranty effective.

1 Exterior Maintenance

To remove of dirt, grime, and bird droppings, use a mild solution of dishwashing detergent at approximately one teaspoon per gallon of warm water. Once clean, follow up with a water based insect spray to kill the spiders around the base and main housing of the unit.

DO NOT use a petroleum based insect spray.

DO NOT use any solvent or corrosion inhibiting products on any part of the unit. This can cause serious stress cracking of the engineered resins and will void warranty.

2 Interior Maintenance

! Note

Before attempting the following maintenance procedures, turn off the power to the unit at the power supply panel.

DO NOT spray any solvents on the electrical components. Solvents will cause stress cracking of the polymeric materials and will void warranty.

3 Lighting Assembly

To test the lighting assembly, the photocell should be covered with a piece of black tape and in about 2-3 minutes the light should illuminate. If this does not occur, the following items should be checked: photocell and bulb.

Parts

Save 10% When You Buy Parts and Pedestals Online!

Please visit www.dockboxes.com for a full parts listing.

To request a parts handbook:

- Call 1-800-559-4269 or
- E-mail sales1@ultimatemarinesource.com

Base Diagram

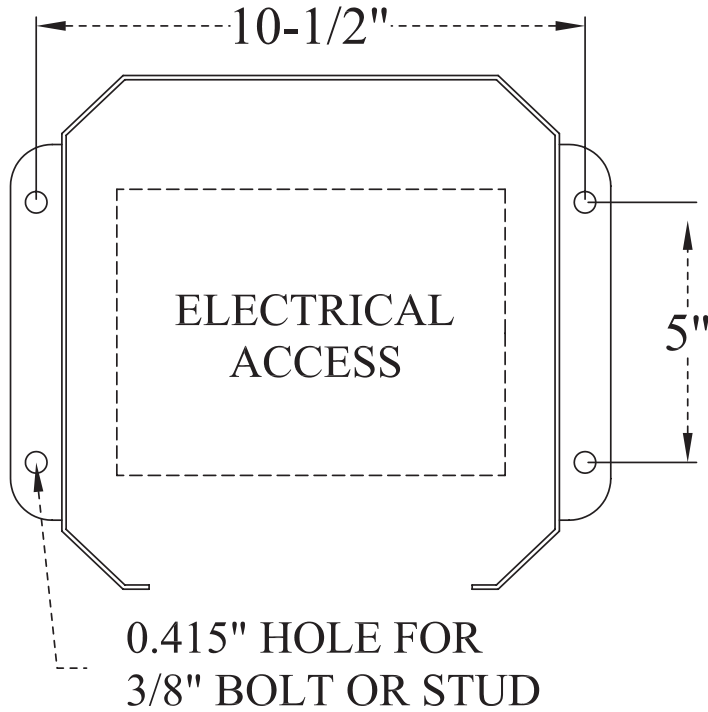

Dimensions

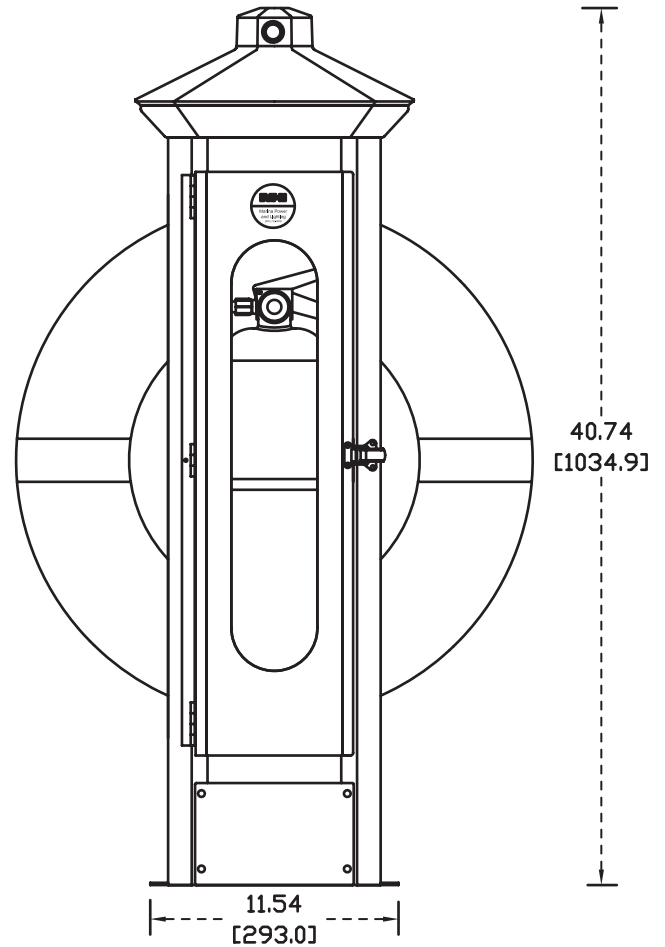

Warranty Policy

Dock Boxes Unlimited, Inc. ("Seller") Warranty Policy Supplement to Seller's Selling Policy 25-000.

This Warranty Policy is intended to only supplement and/or alter the "Warranty" provision of Seller's Selling Policy 25-000. All other terms and conditions contained in the Selling Policy 25-000 remain in full force and effect.

Warranty for Pedestals and Distribution Equipment Housings for Dock Boxes Unlimited, Inc. Products

Seller warrants that the housings of all Pedestals and Distribution Equipment manufactured by it ("Housings") will conform to Seller's applicable specifications and be free from failure due to defects in workmanship and material for the lifetime of the Product.

In the event the Housing fails to comply with the foregoing warranty Seller will, at its option, either (a) repair or replace the defective Housing, or defective part or component thereof, F.O.B. Seller's facility freight prepaid, or (b) credit Buyer for the purchase price of the Product. All warranty claims for Housings shall be made in writing. Seller requires all non-conforming Products be returned at Seller's expense for evaluation unless specifically stated otherwise in writing by Seller.

This warranty does not cover failure or damage due to storage, installation, operation or maintenance not in conformance with Seller's recommendations and industry standard practice or due to accident, misuse, abuse or negligence. This warranty does not cover reimbursement for labor, gaining access, removal, installation, temporary power or any other expenses, which may be incurred in connection with repair or replacement.

This warranty does not apply to equipment not manufactured by Seller. Seller limits itself to extending the same warranty it receives from the supplier.

Warranty for Internal Components for Dock Boxes Unlimited, Inc. Products

Dock Boxes Unlimited, Inc. internal component products are covered under the warranty set forth in Seller's Selling Policy 25-000.

Warranty for Meters for Dock Boxes Unlimited, Inc. Products

Seller warrants that the meters manufactured by it ("Meters") will conform to Seller's applicable specifications and be free from failure due to defects in workmanship and material for five (5) years.

In the event a Meter fails to comply with the foregoing warranty Seller will, at its option, either (a) repair or replace the defective Meter, or defective part or component thereof, F.O.B. Seller's facility freight prepaid, or (b) credit Buyer for the purchase price of the Product. All warranty claims for Meters shall be made in writing. Seller requires all non-conforming Products be returned at Seller's expense for evaluation unless specifically stated otherwise in writing by Seller.

This warranty does not cover failure or damage due to storage, installation, operation or maintenance not in conformance with Seller's recommendations and industry standard practice or due to accident, misuse, abuse or negligence. This warranty does not cover reimbursement for labor, gaining access, removal, installation, temporary power or any other expenses, which may be incurred in connection with repair or replacement. This Warranty is void if factory seal is broken.

This warranty does not cover wire harnesses, Current Transformers (CTs) and counters. These components are covered under selling policy 25-000.

This warranty does not apply to equipment not manufactured by Seller. Seller limits itself to extending the same warranty it receives from the supplier.

Dock Boxes Unlimited, Inc.
5605 North MacArthur Blvd., Ste 200
Irving, TX 75038-2630
United States
1-800-559-4269
fax: 972-402-9995
www.dockboxes.com
sales1@ultimatemarinesource.com